



38190 Commercial Court, Slidell, Louisiana U.S.A. 70458  
Ph.(985)847-1104, Fax 1106, Email: [sales@outlandtech.com](mailto:sales@outlandtech.com), Website: [www.outlandtech.com](http://www.outlandtech.com)

# ROV MODEL "OUTLAND 2000"



The “**OUTLAND 2000**” ROV system has 4 major components.

1. ROV.
2. Cable.
3. Power supply/Monitor/Video Overlay.
4. Hand controller.

**1)ROV:** The ROV has 7 basic components. They are:

- a) Camera
- b) Frame
- c) Flotation
- d) Thrusters
- e) Electronics Bottle
- f) Navigation bottle Includes: Compass, gyro, depth.
- g) Lights

- a) **Cameras**, The Primary Camera makes the Outland ROV unique. The camera was actually designed and the ROV was built around it. Standard systems will include 2 cameras, one mounted on a rotating mechanism and can tilt 360<sup>0</sup> for viewing. A slip ring assembly makes this possible.
  - 1) Forward tilting Color camera is the latest Ex-view HAD CCD II chip available. It is a 1/3” CCD with 750 line of resolution and .001 lux. Sensitivity with a 3.6mm lens. 1020 x 508 pixels.
  - 2) Rear fixed but movable UWC-325/p color camera. 750 line resolution. Same specs as forward camera.
- b) **Frame**, The OUTLAND 2000 frame is made of 5052-H32 Aluminum. The frame is bead blasted and protected with anodes. Most components are attached to the frame using aluminum screws and Nyloks. It’s dimension is 28”(71cm) Long x 18”(46cm) wide x 15”(38cm high).
- c) **Flotation**, is a closed cell polyurethane Foam with Fiberglass covering. The foam has been pressure tested to 500 PSI.
- d) **Thrusters**, All four 1 hp thrusters are designed and manufactured by Tecnadyne Inc. The thrusters have their own control electronics built into the housing. It uses a Brushless DC motor with a magnetic coupling to drive the propeller. There are no dynamic shaft seals to wear out. Each thruster outputs 41 lbs of thrust. The ROV has 82 lbs of forward thrust total.
- e) **Electronics bottle**, Where the main umbilical connects, distributes, and processes data to all components on the ROV. It includes several circuit boards, 1ea. 3 & 8 pin male umbilical connectors, 4 ea. 5 pin connectors and 4 ea. 8 pin female connectors. Refer to block diagram 00120001C attached for basic connections. ROVs after sn 507 are completely digital in it’s control of Lights, Cameras, Thrusters and Grabber. This will allow Outland to make changes on the ROV via software updates.

f) **Navigation Bottle**, The navigation module is specially built by Outland. It contains a pressure transducer, compass, gyro and conditioning circuits plus I/Os for reading, optional, CP probes and Altimeter.

It has  $\pm 1^{\circ}$  accuracy when level and  $\pm 3^{\circ}$  accuracy up to  $\pm 30^{\circ}$  tilt and yaw. A gyro is used for auto-heading. It is not affected when near large metal objects. The depth transducer is also included in this bottle.

g) **Lights**, These lights are NEWLY DESIGNED LED lights. They are the 2 ea. UWL-500 with Super Bright LEDs 4300 Lumens (1,920 lux. @1m). They are set to emit light 220 degrees around the ROV for viewing with any camera selected.

The ROV is stored and shipped in a Pelican case # 1660 (with wheels and handle).

**2) CABLE** (C-3400) is special built for Outland and contains 1 CAT5e LAN cable(4 ea. #24AWG tp) & 12 #22awg conductors. C-3406,500 ft(150m)Assembly); C-3411,1000 ft(300m)Assembly.

**3) POWER SUPPLY/OVERLAY/MONITOR** (SCU-1050 & SPS-1080), The power supply contains all circuitry to send 300 VDC down to the ROV. The high voltage lines are monitored with our exclusive LIM (Line Insulation monitor/GFCI) circuit. In the event water leaks into the cable, Electronics Bottle or thrusters the LIM circuit will trip and protect the Operator and ROV from any high voltage damage. Also Included in the SCU is the Video Overlay board. The SCU has all connectors to the hand controller, video monitor, Keyboard and AC power in. Hand Controller (HC-2000), contains all electronics that condition and control the ROV and Video Overlay unit. The Keyboard controls the Video Overlay for time/date, text, graphics and Diagnostics. Included in the Console is a NEW 15" 1700 nit LCD monitor and HDD DVR Video recorder. All mounted in a weatherproof case with handles).

## CONTROL UNIT (SCU-1050) & POWER SUPPLY, (SPS-1080)



- 4) HAND CONTROLLER,** The HC-2000 contains all the electronics that controls the ROV. The Joy-stick has 3 axis control of the ROV. The other switches and buttons control all other functions of the ROV such as Lights, up/down thruster, camera tilt, auto/depth and heading, thruster power level, camera select etc.. (IP64 RATED).

*HAND CONTROLLER, HC-2000*



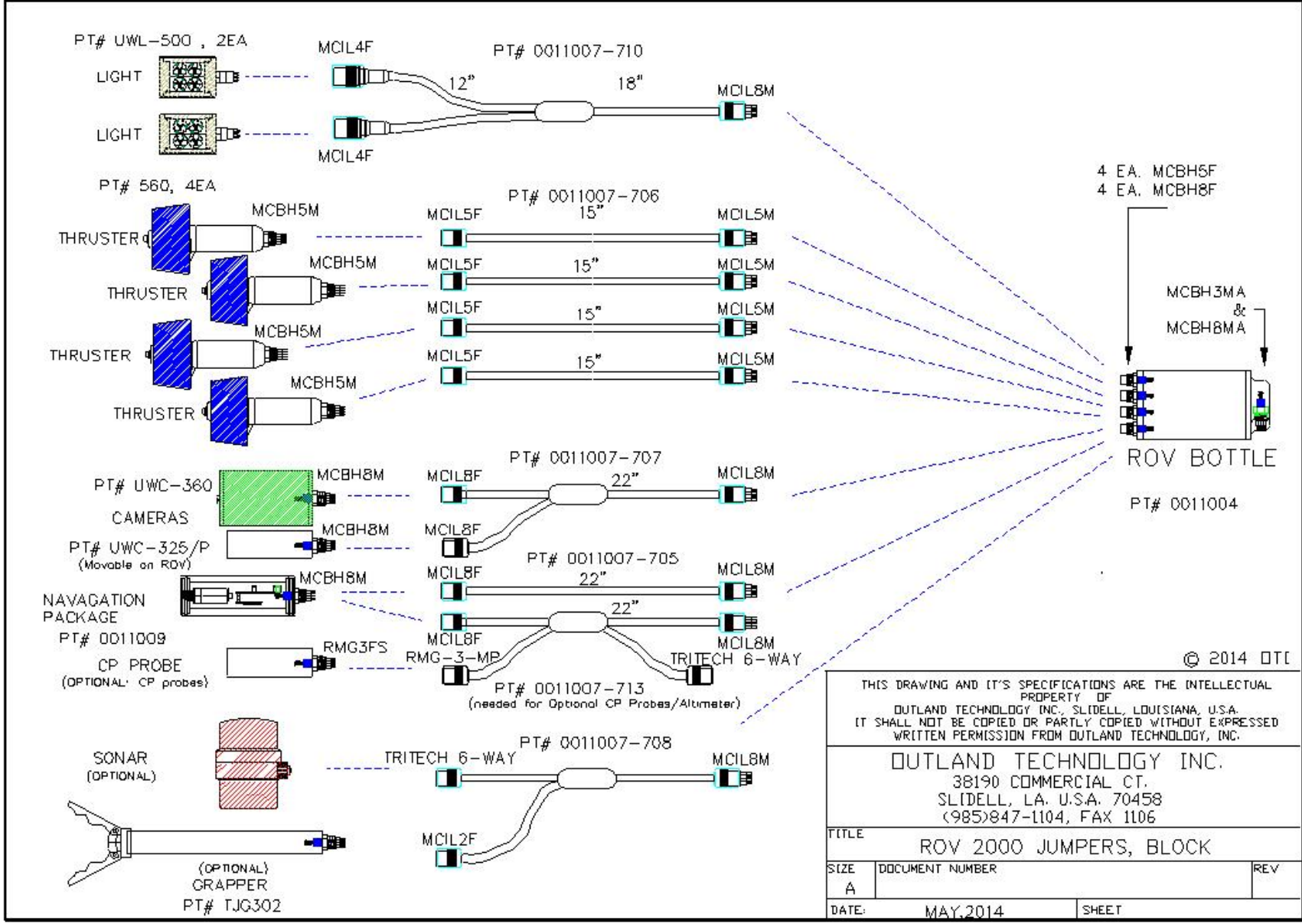

## OPTIONS:

The Outland 2000 ROV can be outfitted with many options. The spare twisted pair in the umbilical can transmit data, video or be used as a trigger for still cameras, and other devices. The Outland ROV has an extra 150 watts of 24 VDC power to power such devices as:

### I. Imaging Sonars,

- a) Obstacle avoidance sonars. 100 meter range 360 degrees sweep.
  - 1) Tritech Micron. [www.tritech.co.uk](http://www.tritech.co.uk)
  - 2) Imagenex 851. [www.imagenex.com](http://www.imagenex.com)
- b) Multi-beam sonars for real time imaging.
  - 1) Blueview, [www.blueview.com](http://www.blueview.com)
  - 2) Didson, [www.soundmetrics.com](http://www.soundmetrics.com)
  - 3) Tritech, [www.tritech.co.uk](http://www.tritech.co.uk)

II. Metal Detector, JW Fisher model RMD1, [www.jwfishers.com](http://www.jwfishers.com)

III. Grabber, Manipulator with 3 jaws for picking up or holding objects.

IV. A second live video camera can be transmitted up the spare twisted pair but a second monitor must be used for viewing.

V. HD IP Camera.

VI. **Future options** we have not thought of yet can use this twisted pair of wires such as Ethernet backbone for IP cameras. An array of sensors, another control signal for updated multi-function grabber, many, many other uses!!

New Optional features are:

- a) Cathodic protection probes can now be used connected to the navigation modules and displayed on screen.
- b) Tritech's Micro Altimeter can be connected to the Nav Module also for use in auto altitude of the ROV.

ALL INFORMATION CONTAINED IN THIS DOCUMENT CAN CHANGE AT ANY TIME. OUTLAND WILL MAKE EVERY EFFORT TO UPDATE THIS AS OFTEN AS POSSIBLE.